



Goldeye

G-130 TEC1

- GigE Vision InGaAs SWIR camera
- SXGA resolution
- Visible and SWIR sensitivity
- Power over Ethernet
- Compact industrial design, no fan

See the invisible

Short-wave infrared (SWIR) cameras with InGaAs sensor technology

Goldeye G-130 TEC1 with Sony IMX990 runs 94.0 frames per second at 1.3 MP resolution.

Goldeye cameras are equipped with InGaAs sensor technology making them sensitive in the short wave infrared spectrum ranging from 900 nm to 1,700 nm. Some models have extended sensitivity in the visible spectrum down to 400 nm. All Goldeye SWIR cameras can be operated at very high frame rates and capture outstanding low-noise images. They are the perfect choice for industrial and scientific applications beyond the visible spectrum. All Goldeye models are available with either a Camera Link or a GigE Vision interface.

Easy software integration with [Allied Vision's Vimba Suite](#) and compatibility to the most popular third party image-processing libraries.

See the [Modular Concept](#) for lens mount, housing variants, optical filters, case design, and other modular options. See the [Customization and OEM Solutions webpage](#) for additional options.

Specifications

Goldeye G-130 TEC1	
Interface	IEEE 802.3 1000BASE-T, IEEE 802.3af (PoE)
Resolution	1280 (H) × 1024 (V)
Spectral range	400 nm to 1700 nm

Goldeye G-130 TEC1	
Sensor	Sony IMX990
Sensor type	InGaAs
Shutter mode	Global shutter
Sensor size	Type 1/2 VSWIR
Pixel size	5 μm \times 5 μm
Lens mount (default)	C-Mount
Max. frame rate at full resolution	94 fps
ADC	12 Bit
Image buffer (RAM)	256 MByte
Cooling temperature	+5 $^{\circ}\text{C}$, +20 $^{\circ}\text{C}$ (default and calibrated), +35 $^{\circ}\text{C}$, +50 $^{\circ}\text{C}$, or user-configurable
Dark current	4,800 e^{-}/s (at +20 $^{\circ}\text{C}$ FPA temperature)
Temporal dark noise	250 e^{-} (Gain0), 210 e^{-} (Gain1)
Saturation capacity	165 ke^{-} (Gain0), 17.2 ke^{-} (Gain1)
Dynamic range	56.4 dB (Gain0), 38.2 dB (Gain1)
Output	
Bit depth	8 - 12 Bit
Monochrome pixel formats	Mono8, Mono12, Mono12Packed
General purpose inputs/outputs (GPIOs)	
TTL I/Os	1 input, 1 output
Opto-isolated I/Os	1 input, 2 outputs
RS232	115 200 Baud, 8N1 (adjustable)
Operating conditions/dimensions	
Operating temperature	-20 $^{\circ}\text{C}$ to +55 $^{\circ}\text{C}$ (housing)
Power requirements (DC)	10.8 V DC to 30.0 V or via PoE
Power consumption	10.8 W (at 12 VDC), <12.95 W (PoE)
Mass	344 g
Body dimensions (L \times W \times H in mm)	78 \times 55 \times 55
Regulations	CE: 2014/30/EU (EMC), 2011/65/EU, incl. amendment 2015/863/EU (RoHS); FCC Class B

Quantum efficiency

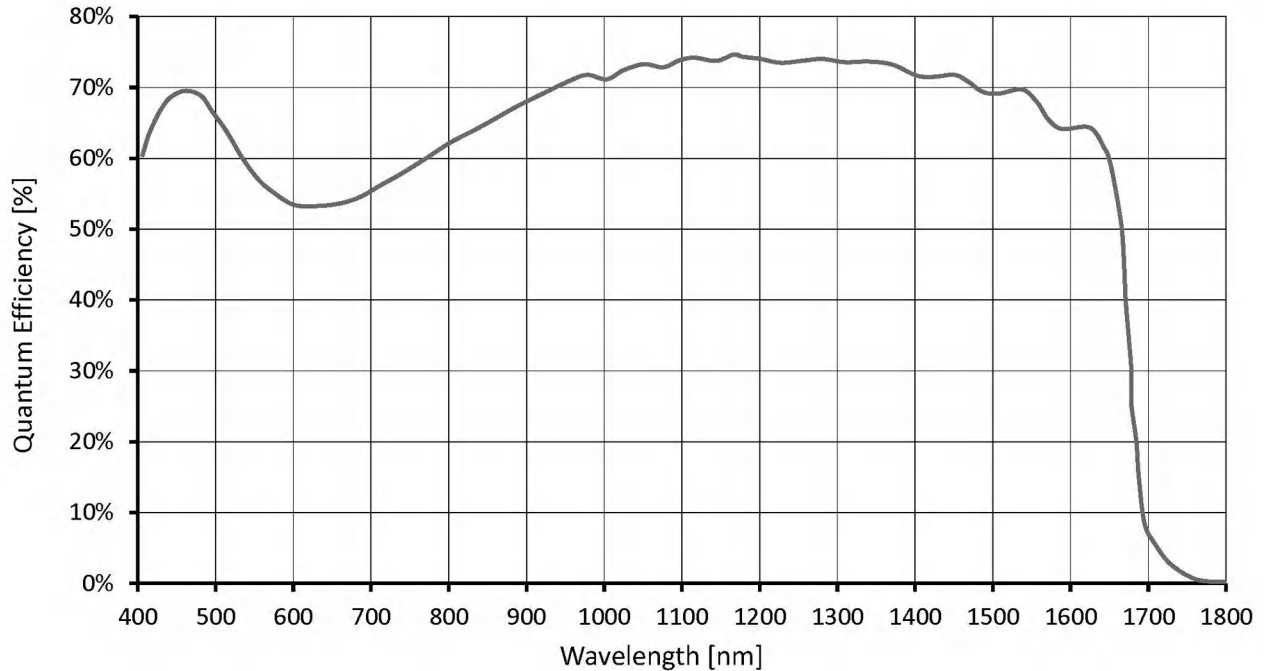

Features

IR-specific features (camera and sensor)

- Integrated correction data sets, compensation of sensor inhomogeneity and underlying structures (non-uniformity correction - NUC)
- Defect pixel correction
- Background correction
- Automated and manual sensor temperature management via TEC features
- Temperature status indicator
- Temperature specific events

General features

- Automatic exposure time control
- Gain (analog)

- I/O configuration and trigger control
- Stream hold (deferred image output)
- Storable user sets
- Firmware update in the field
- Region of interest (ROI) control, look-up table (LUT) support, as well as various auto features

Goldeye cameras are compatible with Allied Vision's Vimba SDK. Moreover, in combination with our AcquireControl software, extensive image analysis functions are available:

- Pseudo color LUT with several color profiles
- Auto contrast
- Auto brightness
- Analyze multiple regions (rectangular, circle) within the image
- Real-time statistics and histogram display

Technical drawing

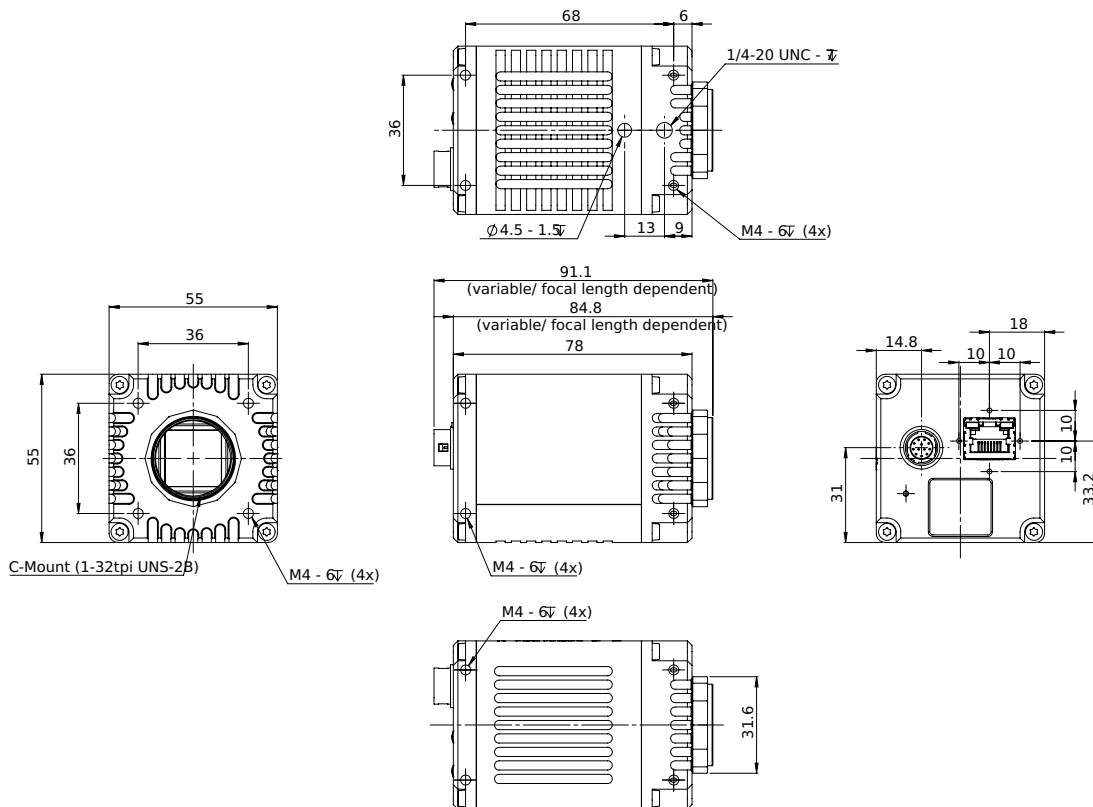

Applications

Goldeye cameras are very sensitive in the SWIR spectrum. They can be used in an extended operating temperature range. Thanks to temperature stabilization and integrated image correction, Goldeye cameras achieve an outstanding image quality with little noise and a high dynamic range. They are well-suited for many typical SWIR applications in various industry branches:

- Semiconductor industry: solar cell and chip inspection
- Recycling industry: plastics sorting
- Medical imaging, sciences: hyper- and multi-spectral imaging, microscopy, optical coherence tomography (OCT)
- Metal and glass industry: thermal imaging of hot objects (250 °C to 800 °C)
- Agriculture industry: airborne remote sensing
- Printing industry: banknote inspection
- Electronics industry: laser beam profiling
- Surveillance and security: vision enhancement (for example, seeing through fog)

White Paper To learn more about typical application fields for SWIR cameras, download our White Paper: [Seeing beyond the visible – short-wave infrared \(SWIR\) cameras offer new application fields in machine vision.](#)